

optris® Industrial process interface

TECHNICAL DATA

Features:

- Industrial process interface with 3 analog / alarm outputs, 2 analog inputs, 1 digital input, 3 alarm relays
- 500 VAC_{RMS} isolation voltage between camera and process
- Separate fail-safe relay output
- PI/Xi hardware including all cable connections and PIX Connect software are permanently observed during operation



General specifications

Environmental rating	IP65 (NEMA-4)
Ambient temperature	-30 °C ... 85 °C
Storage temperature	-30 °C ... 85 °C
Relative humidity	10–95 %, non condensing
Vibration	IEC 60068-2-6 (sinusoidal form) IEC 60068-2-64 (broadband noise)
Shock	IEC 60068-2-27 (25 G and 50 G)
Weight	610 g (with 5 m cable)
Cable length	5 m HT cable (standard), optional 10 m and 20 m

Technical images

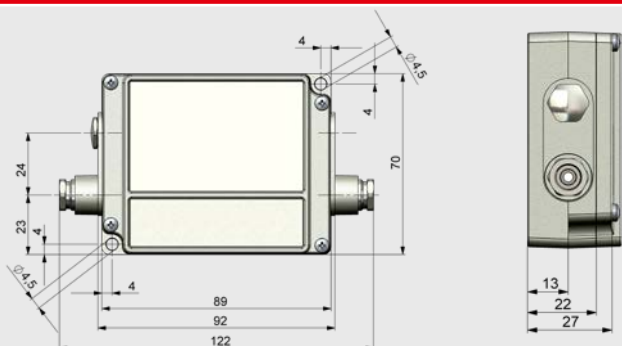

Electrical parameters

Power supply	5–24 V DC
LED display	2 green LEDs for power and fail-safe/ 3 red LEDs for alarm relay status
Isolation	500 VAC _{RMS} between PI/Xi camera and process
Outputs	3 analog / alarm outputs 3 alarm relays ¹⁾
Inputs	2 analog inputs 1 digital input
Ranges	0/4–20 mA (for AO 1–3) 0–30 V / 400 mA (for alarm relays DO 1–3) 0–10 V (for AI 1–2) 24 V (for DI)

¹⁾ Active if AO1, 2 or 3 are programmed as alarm output

Programmable features

Analog inputs	<ul style="list-style-type: none"> • Emissivity setting • Ambient temperature compensation • Reference temperature • Uncommitted value • Flag control • Triggered snapshots, triggered recording, triggered line scan camera, triggered event grabber • Reset peak-/valley-hold
Digital input	<ul style="list-style-type: none"> • Flag control • Triggered snapshots, triggered recording, triggered line scan camera, triggered event grabber • Reset peak-/valley-hold
Analog outputs	<ul style="list-style-type: none"> • Main measure area • Measure area • Internal temperature • Flag status • Alarm • Frame sync. • Fail-safe • External communication • Center pixel (direct output)*

^{*)} Available only for the models PI 1M / PI 05M

Example for a fail-safe monitoring of the PI with a connected PLC

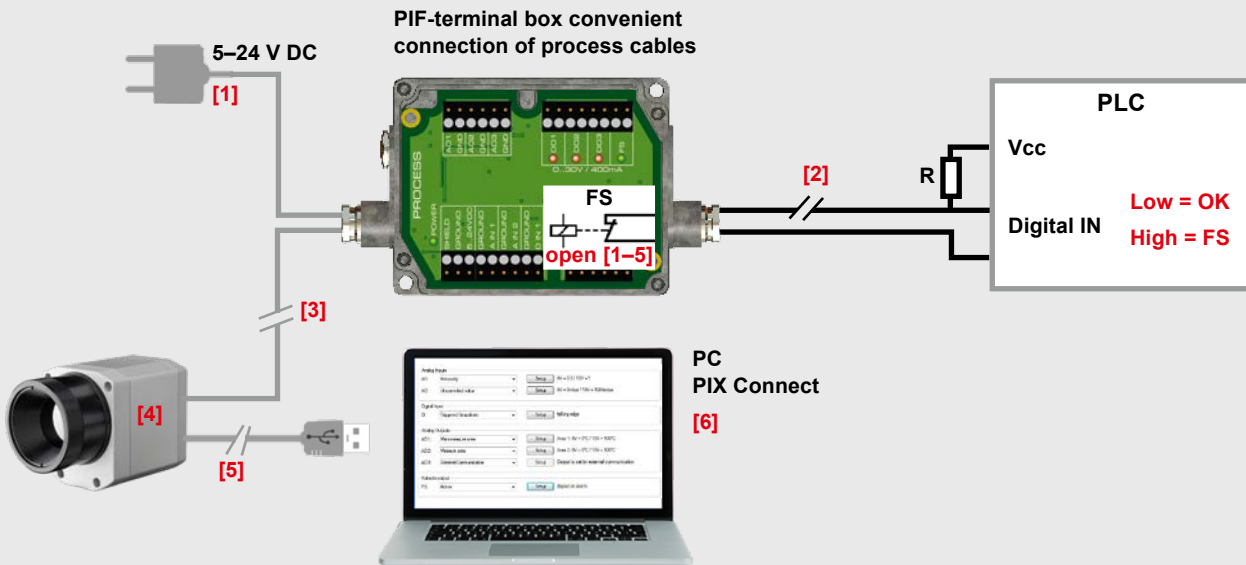

Fail-safe monitoring states

- [1] Breakdown of PIF power supply
- [2] Cable break of fail-safe cable
- [3] Interruption of cable PI – PIF
- [4] Malfunction of PI camera
- [5] Breakdown of PI power supply/ Interruption of USB cable
- [6] Malfunction of PIX Connect software

Fail-Safe status:

Normal:	Relay closed	LED on
Alarm:	Relay open	LED off

Snapshot of programmable features